

# F SERIES

# W3-1319SA

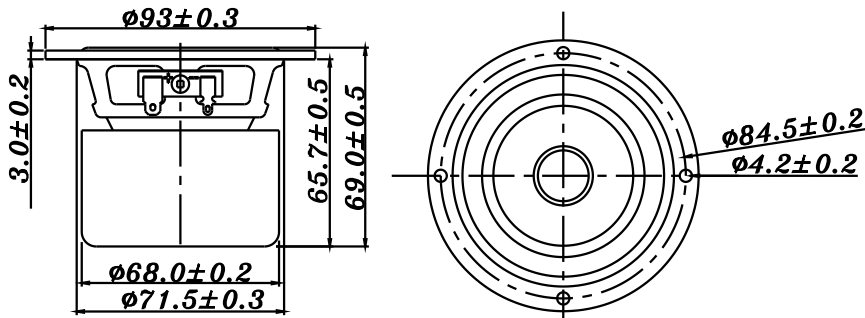

- FULL RANGE FREQUENCY RESPONSE
- HIGH POWER LOADING DESIGN
- STAMPING STEEL BASKET, VC VENTED DESIGN
- BAMBOO FIBER PAPER CONE WITH SANTOPRENE SURROUND
- MAGNETICALLY SHIELDED
- UNDERHUNG MOTOR DESIGN
- LOW 2nd, 3rd DISTORTION DESIGN

## 3" PAPER FULL RANGE

DIAPHRAGM MTL	Paper
SURROUND MTL	Santoprene
NOMINAL IMPEDANCE	8 $\Omega$
DCR IMPEDANCE	6.6 $\Omega$
SENSITIVITY 1W/1m	86 dB
FREQUENCY RESPONSE	110 - 20K Hz
FREE AIR RESONANCE	110 Hz
VOICE COIL DIAMETER	18.4 mm
AIR GAP HEIGHT	6 mm
RATED POWER INPUT	12 W
MAXIMUM POWER INPUT	25 W
FORCE FACTOR, BL	3.53 TM
TYPE OF MAGNET	Ferrite
MOVING MASS	1.74 g
FERROFLUID ENHANCED	No
SUSPENSION COMPLIANCE	1215 $\mu\text{MN}^{-1}$
EFFECTIVE PISTON AREA	0.0032 $\text{M}^2$
Levc	0.012 mH
Zo	31 $\Omega$
X-max	0.5 mm
Vas	1.77 Liter
Qts	0.55
Qms	2.96
Qes	0.68

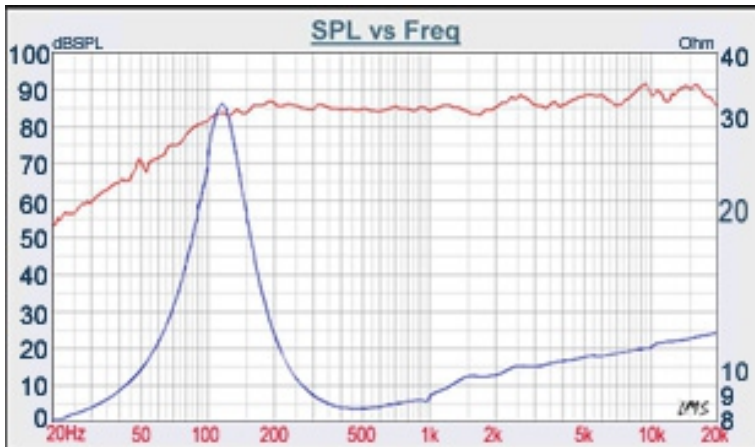

**TB** SPEAKERS

VOICE: 886.2.26570282 FAX: 886.2.26580166  
E-MAIL: info@tb-speaker.com